

PROGRAMMING THE TRANSMITTER

Thank you for your purchase of the Skylink garage door remote control, Model 89. There are 3 different steps you need to setup in order to use this universal garage door remote control to operate your existing garage door opener. These 3 steps are:

- 1) Frequency switch – select the correct frequency according to the brand of your existing garage door opener. Refer to Step 1.
- 2) Brand jumpers – place the brand jumpers at the correct position according to the brand of your existing garage door opener. Refer to Step 2.
- 3) Code setting – Set the DIP switch on the Model 89 so that they match the code setting of your existing garage door opener. Refer to Step 3 or Step 4 depending on the brand of your garage door opener.

Please follow the detailed instructions below in order to set-up the Skylink Model 89 to work with your existing opener.

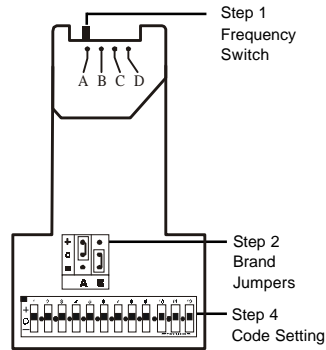

STEP 1 - SET FREQUENCY SWITCH

- 1a. Locate frequency switch on the top of the transmitter: (See diagram A)
- 1b. Determine the brand of your garage door opener and set the frequency switch to the corresponding position. (See chart 1)

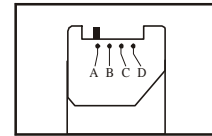

Diagram A

	A	B	C	D
USA	300	310	318	390
CANADA	310	315	318	390

Brand of your opener	USA		CANADA	
	Set switch to position	Frequency	Set switch to position	Frequency
Chamberlain®	D	390	B/D	315/390
Lift-Master®	D	390	B/D	315/390
Sears®	D	390	B/D	315/390
Wayne Dalton®	A/D	300/390	B/D	315/390
Master Mechanic®	D	390	B/D	315/390
Genie®	D	390	B/D	315/390
Overhead®	D	390	D	390
Pulsar/Allister/Allstar®	C	318	C	318
Linear® MegaCode™	C	318	C	318
Linear®	B	310	A	310
M-O-Matic®	B	310	A	310
Stanley®	B	310	A	310
Multi-Code®	A/B	300/310	A	310
Martec/Teckey®	A	300	-	-
Skylink® UR-100	D	390	D	390

Chart 1

STEP 2 - SET BRAND JUMPERS

- 2a. The Model 89 contains 2 brand jumpers and 12 DIP switches (see diagram B). The brand jumpers are located just above the DIP switches with markings "A" and "B". There are 2 connectors, one is placed on the "A" column, the other one is placed on the "B" column. For each column, there is a connector. If the connector is placed on the top and middle post of that column, that column is set on "+". If the connector is placed on the middle and bottom posts, that column is set on "-". If the connector is removed completely, that column is set on "0" (see diagram B). In order for the Model 89 to work with your existing garage door opener (motor), you need to set the brand jumpers based on the brand of your existing garage door opener. Please set these 2 brand jumpers "A" and "B" based on the brand jumpers setting on chart 2. Please identify the group number on chart 2 in order to determine which is the next step to proceed.

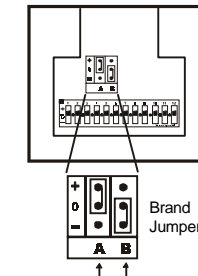

A = "+" B = "-"
REMOVE JUMPER = "0"

Diagram B

For garage door openers belonging to groups 1 to 3, please follow step 3 of the procedures, this will complete the setup. No need to proceed to step 4.

For garage door openers belonging to groups 4 to 8, you can proceed directly to "Step 4 – Set Code Connector" after you have successfully set the brand jumpers. Please skip step 3 below.

STEP 2 - SET BRAND JUMPERS

Group	Brand	Brand jumpers setting		Proceed to
		A	B	
1	Chamberlain®, Sears®, Lift-Master® (without DIP switches but with red, orange or green learn button)	-	+	Proceed to Step 3.
2	Chamberlain®, Lift-Master®, Sears®, Wayne Dalton®, Master Mechanic® (without DIP switches but with yellow, white, or gray learn button)	0	-	
3*	Genie® Intellicode™ (without DIP switches)	+	+	Proceed to Step 4, skip Step 3.
4	Genie® (with DIP switches), Overhead®	0	+	
5	Chamberlain®, Lift-Master®, Sears®, Wayne Dalton®, Master Mechanic® (with DIP switches)	+	-	
6	Stanley®, Multi-Code®, Martec®	-	-	
7	Linear®, Moore-O-Matic®	+	0	
8	Pulsar®, Allstar®, Allister®, Linear® MegaCode™	-	0	

Chart 2

* Note:

For Genie® Intellicode™, if the brand jumper for group 3 cannot operate your garage door opener properly, please use setting A "+", B "-".

STEP 3 - LEARN CODE

Note:

Proceed to this step only if the brand of your garage door opener belongs to either group 1, 2 or 3 on chart 2. Otherwise, proceed to Step 4 - Set DIP switches.

- 3a. If your existing garage door opener belongs to any brand from group 1, 2 or 3, then you should find a "learn" button from the garage door opener (the unit with the motor located on the ceiling of your garage, see diagram C). Press this learn button for approximately 2 seconds. The LED light beside the learn button will go on and then enter the current 4-digit PIN, on the keypad of the Model 89, then press [#] key. If you have just purchased the Model 89, the factory default 4-digit PIN is 0000. So please enter [0], [0], [0], [0], [#]. This will activate the Model 89 and radio signal will be sent to your existing garage door opener. If the garage door opener learns the code, the LED light on the garage door opener will flash then go off. The Model 89 is now programmed to your existing garage door opener and will operate your garage door. Programming is now completed and please refer to "Keypad Operation" for changing your personal PIN and other operations.

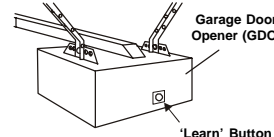

Diagram C

STEP 4 - SET DIP SWITCHES

Note:

Proceed to this step only if the brand of your garage door opener belongs to either group 4, 5, 6, 7 or 8 on chart 2. Otherwise, proceed to Step 3 - Learn code.

- 4a. If the brand of your garage door opener belongs to groups 4 to 8, that means you need to program the correct DIP switch setting in order for the Model 89 to work with your existing garage door opener. There are 12 DIP switches numbered from 1 to 12. (see diagram D)
- 4b. Use a pen to set the DIP switches to match the code of your existing transmitter or receiver.

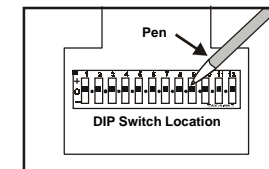

Diagram D

Each DIP switch of this keypad has 3 positions ("+", "0", "-"). If the switches of your existing receiver (Stanley®, Genie®, Multi-Code®, Linear®, Moore-O-Matic®, Martec®) have only two positions, set the switches of the model 89 to "+" for ON or CLOSE, and "-" for OFF or OPEN (Do not use "0" center position.) (see diagram E). If the switches of your existing transmitter (Chamberlain®, Sears®, Lift-Master®, Wayne Dalton®, Pulsar® or Master Mechanic®) have 3 positions, set the DIP switches of the model 89 to match their corresponding positions.

Examples of how to set Model 89

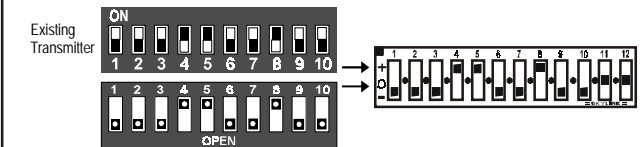

Diagram E

STEP 4 - SET DIP SWITCHES

Code connector setting to match your opener/motor

Linear	Position 1 to 8	+ OR -	
M-O-M	Position 1 to 8	+ OR -	
Stanley (310) Canada	Position 1 to 10	+ OR -	11,12 set to '+' or '-'
Stanley (300)	Position 1 to 10	+ OR -	11,12 set to '+' or '-'
Multi-Code	Position 1 to 10	+ OR -	11,12 set to '+' or '-'
Chamberlain	Position 1 to 9	+ , 0 , OR -	
Lift-Master	Position 1 to 9	+ , 0 , OR -	
Sears	Position 1 to 9	+ , 0 , OR -	
Wayne Dalton	Position 1 to 9	+ , 0 , OR -	
Master Mechanic	Position 1 to 9	+ , 0 , OR -	
Genie (9 positions)	Position 1 to 9	+ OR -	
Genie (12 positions)	Position 1 to 12	+ OR -	
Overhead	Position 1 to 9	+ , 0 , OR -	
Martec/Teckey	Position 1 to 10	+ OR -	11,12 set to '+'
Pulsar/Allister/Allstar	Position 1 to 9	+ , 0 , OR -	

4c. If your existing transmitter or receiver has fewer than 12 switches, match only the first corresponding DIP switch. Leave the remaining posts in center position "0".

4d. Enter the current 4-digit PIN, on the keypad of the Model 89, then press [#] will activate the garage door opener. If you have just purchased the Model 89, the factory default 4-digit PIN is 0000. So please enter [0], [0], [0], [0], [#]. If the garage door does not open, reverse all of the DIP switch on the model 89. The "+" will be changed to the "-" position and the "-" position will be changed to the "+" position (see diagram F). Also try the unused DIP switches in the "+", "0" or "-" positions.

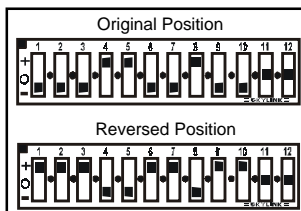

Diagram F

If your Sears®, Chamberlain® or Lift-Master® transmitter has three buttons (two small, one large) (Diagram G) then the button that operates the receiver will determine how to set the number 1 DIP switch of the Skylink transmitter. If the large button is used to operate the unit, set the #1 DIP switch to "-" position; if the middle button is used, set the #1 DIP switch to the center position; if the button at the end is used, set the #1 DIP switch to "+" position. Set the other DIP switches (DIP switch #2 onward) to match the setting of your existing transmitter.

Note - 'LEARN CODE' Some transmitters/receivers do not have DIP switches, this means they can "learn" new code settings. Just set the DIP switches on our keypad to any code combination. Press the learn button, (located on the back of the garage door receiver located in the ceiling of the garage), for 2 seconds then release, so that the light beside the learn button goes on.

While the light is on, enter the 4 digit pin number, (currently set at 0000), then press the [#] key. If the light beside the learn button flashes, the operator has now learned and will recognize the keypads code.

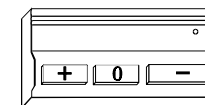
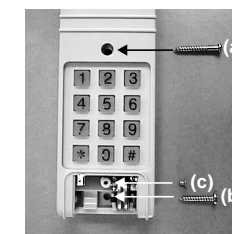

Diagram G

INSTALLATION

- Position the keypad on the garage door frame.
- Lift up the cover and insert screw above the keypad in the slot provided (a).
- Remove the battery cover and insert the second screw in the lower slot (b).
- Replace the battery cover and insert screw (c).



KEY PAD OPERATION

NOTE:

The backlight comes on and a beep is emitted when any key is pressed. The backlight of the key pad may not be visible when it is too bright outside. When any key is pressed, the next key must be pressed within 5 seconds or the backlight turns off and the sequence is canceled. You must begin again.

If the keypad does not emit a beep when pressed, wait a few seconds and press the key again. If you hear a beep, the keypad has accepted that key.

- To change your PIN:

1. Enter the current PIN, (currently set at 0 0 0 0), press * ,
2. Enter new 4 digit PIN, press * ,
3. Enter new PIN again, press * .

For example, if you are changing the PIN number from 0000 to 1234, enter the following sequence, 0000, *, 1234, *, 1234, * . If confirmed, the backlit LED flashes and the unit emits a long beep.

- Operation

Press [PIN] , [#] To open or close garage door, press your four digit PIN and the [#] key. If confirmed, the model 89 will emit three beeps.

If you do not hear 3 beeps after the 4-digit PIN and [#] is entered, that means you have entered an incorrect PIN, and the Model 89 will not operate your garage door.

WARNING

If this transmitter triggers other garage doors in your neighborhood, change all your transmitters and receiver to a new code setting.

DO NOT let children use the garage door transmitter without adult supervision. Children can injure themselves or others by the garage door.

WARRANTY

If, within one year from date of purchase, this product should become defective (except battery), due to faulty workmanship or materials, it will be repaired or replaced, without charge. Proof of purchase is required.

BATTERY

Two 3 volt Lithium type (CR2032) batteries (included).

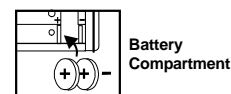

It is time to change the batteries when the backlight no longer appears.

FCC

The Universal Garage Door Remote Control is approved by the FCC and it complies with Part 15 of the FCC Rules. Its operation is subject to the following two conditions :

1. This device may not cause harmful interference.
2. This device must accept any interference that may cause undesired operation.

WARNING:

Changes or modifications to this unit not expressly approved by the party responsible of compliance could void the user's authority to operate the equipment.

NOTE

If your Skylink Universal Remote Control does not activate your Garage Door Opener, the reason may be that your GDO age or manufacturer is not listed on the compatibility chart.

The solution is the Skylink UR-100 Universal Receiver.

If you would like to order Skylink's product or have difficulty getting your Skylink's remote control to work, please :

1. visit our website FAQ at www.skylinkhome.com, or
2. email us at support@skylinkhome.com (reply within 24 hrs)
3. call our toll free at 1-800-304-1187 from Monday to Friday, 9 am to 5 pm EST.

Skylink will not be held liable or responsible for any misuse or application of this product other than for its intended use.

CUSTOMER SERVICE

2213 Dunwin Drive
Mississauga, Ontario,
L5L 1X1, CANADA
(905)608-9223
(905)608-8744 FAX
Email:support@skylinkhome.com
(Reply within 24 hrs)
Customer Service : (800)304-1187
From 9am to 5pm EST (Mon-Fri)
<http://www.skylinkhome.com>
P/N. 101A190 Rev.0
Patent no. 5680134, 5841390,
6005508
Patents Pending
©2003 SKYLINK GROUP



WIRELESS
KEYLESS ENTRY
USER'S INSTRUCTIONS
(Model 89)

© are registered trademarks of their respective corporations

