

Door/Window Alert

Model WD-434

1. INTRODUCTION

The Door/Window Alert is designed to monitor any door or window within your house. When the monitored window or door is opened, the receiver will alert you. It will beep and flash.

In this package, you should find a sensor, a magnet, a Household Alert® receiver, an adapter, 3V lithium battery, a clip and other mounting accessories.

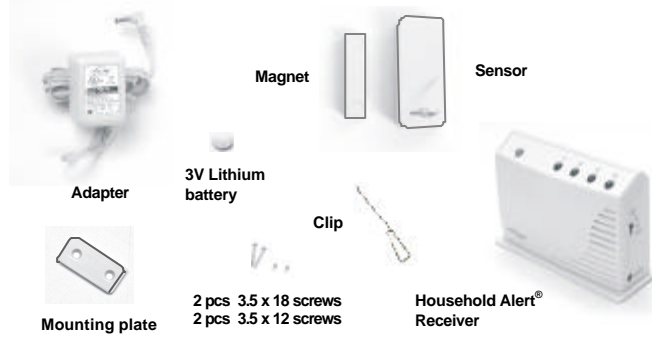

Please follow the instructions below to set up the door / window sensor and the receiver.

2. SET UP CODE CONNECTORS AND ZONE CONNECTORS

1. CODE CONNECTORS

In order for the sensor to communicate with the receiver properly, the sensor's code must match with the receiver's code. Code connectors 1 to 6 can be found by opening the top cover of the sensor and the back cover of the receiver. User is required to set these code connectors randomly and the code settings on the sensor and receiver must be the same. Each position of the code connector can be set to "+", "-", or "0" position. Refer to the diagram below to set the code connectors properly. If the connector is placed on the top and middle posts, that column is set on "+". If the connector is placed on the middle and bottom posts, that column is set on "-". If the connector is removed completely, (not placed on any posts), it is set to "0". (see diagram for examples of how to set a column to the three different positions).



Open the top cover

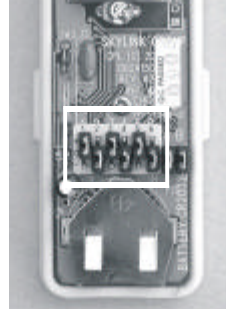

Code Connectors on Receiver

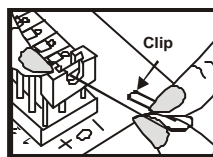

Code Connectors on Sensor

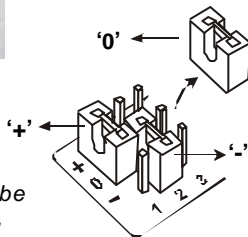

Note: A connector can be removed with the clip, as shown.

Note: If you experience interference from a nearby system, which could accidentally trigger your system, please change the code settings on the sensor and receiver. The code setting on the sensor and receiver should still match after changing the code setting.

2. SET UP CODE CONNECTORS AND ZONE CONNECTORS (CONT)

2. ZONE CONNECTORS

Each receiver can work with up to 4 different sensors (to represent 4 different zones on the receiver). There are 2 connectors that determine the zone number 1, 2, 3 and 4. These 2 connectors can be found by opening the top plastic cover, near the code connectors with marking "A" & "B". Please follow table 1 to set the zone.

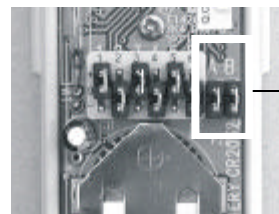

Zone connectors

	A	B
Zone 1	+	+
Zone 2	+	-
Zone 3	-	+
Zone 4	-	-

Table 1

"+" in the table means the connector for that position should be placed on the posts.

"-" in the table means the connector for that position should be removed.

3. POWER UP THE HOUSEHOLD ALERT® RECEIVER AND DOOR/WINDOW SENSOR

After setting up all the connectors, both units are ready to be powered up.

Plug in the adapter to the receiver, the green LED will start flashing indicating the receiver unit is powered up but no sensor is detected. Remove the top cover of the sensor and insert the 3V lithium battery to the sensor as shown in the diagram.



Plug in the adapter to the receiver

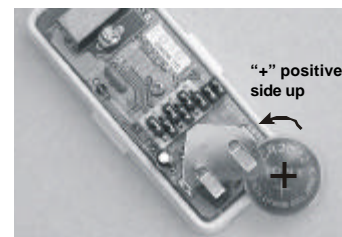

Insert 3V lithium battery to the sensor

Before inserting the battery, keep the magnet away from the sensor. After inserting the battery to the door / window sensor, the receiver will beep and flash. If the door / window sensor is set to zone 1, zone 1 red LED will flash. The beeping and flashing will continue until the magnetic contact is close to the sensor.

You are now ready to install the sensor and the magnet to a door or window.

Note: The receiver may not be able to receive the signal from the sensor properly if they are too close to each other. Move the sensor further from the receiver to test again.



When the magnetic contact is closed, the receiver will not beep.



When the magnetic contact is broken (open), the receiver will beep and a LED will flash.

4. INSTALLATION

SELECT A MOUNTING LOCATION

The sensor should be mounted on the door / window frame and the magnet should be mounted on the door / window itself. Mount the sensor or magnet as high as possible.

You should find a grey alignment marking on one side of the sensor. The magnet should be in contact with this marking when the door / window is closed (Refer to Diagram A).

If the surface of the frame is flat enough, double-sided foam tape is sufficient, otherwise, it is recommended to use the mounting plate and screws as well.

After mounting the sensor, put the cover back on with the Household Alert® logo in the upright position.

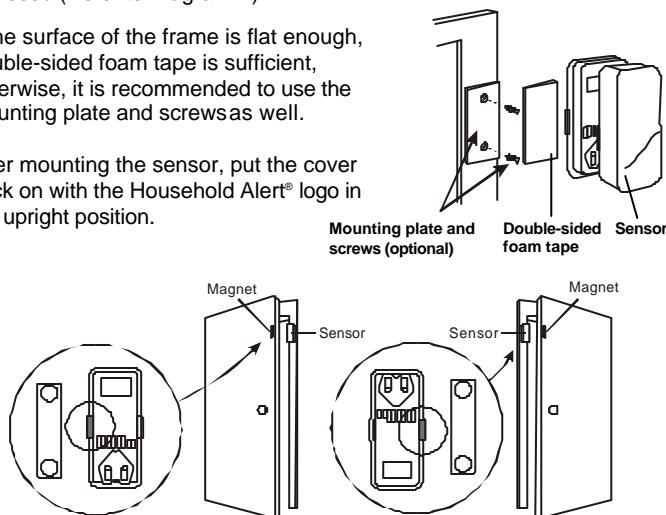

5. OPERATION

When the magnetic contact is broken, such as when the door or window is open, the sensor will send a signal to the receiver, and the receiver will beep and the corresponding zone red LED will flash.

If the sensor is set to zone 1, zone 1 red LED on the receiver will flash, and the receiver will emit a continuous "single beep", i.e. "beep" pause, "beep", pause..... etc.

If the sensor is set to zone 4, zone 4 red LED will flash, and the receiver will emit a continuous "4 beeps", i.e. "beep beep beep beep" pause "beep beep beep beep" pauseetc.

By the number of beeps emitted by the receiver, user can identify which zone is triggered.

6. BUZZER VOLUME

You can select the buzzer volume by switching the volume switch to "HI" or "LO" position.

The buzzer can be disabled by switching to the "OFF" position.



7. MUTE

When a sensor is triggered for a long period of time, you may stop the buzzer by pressing the mute button. When another signal comes again, you can disable the buzzer for all currently activated sensors by pressing the mute button. The receiver will beep again if it receives another signal.

For instance, if you know the door / window sensor will be on for a while when another family member is cleaning the window, you may want to disable the buzzer for this sensor. Then you can press the "Mute" button after it starts to sound. If any other sensor is triggered, the receiver will sound again.



8. LOSS OF SIGNAL INDICATION

When the battery level on the sensor drops to a certain level, or the sensor is out of the operating range, the receiver will show a "loss of signal" indication. The red LED representing that zone will flash rapidly, i.e. if zone 1 sensor is lost, the zone 1 red LED will flash rapidly.

When the loss of signal indication occurs, move the receiver closer to the corresponding sensor and trigger that sensor. If the red LED stops flashing rapidly, that means the receiver or sensor needs to be relocated. If the "loss of signal" indication persists, replace the battery of that sensor.

9. OTHER HOUSEHOLD ALERT® SENSORS

The Household Alert® receiver can work with up to 4 different sensors: garage door monitor sensors, door / window sensors, water sensors, indoor/outdoor motion sensors, etc. Please visit www.skylinkhome.com or contact us at support@skylinkhome.com for more information of how to fully utilize your Door/Window Alert.



10. WARRANTY

If, within one year from date of purchase, this product should become defective (except battery), due to faulty workmanship or materials, it will be repaired or replaced, without charge. Proof of purchase and a Return Authorization are required.

11. CUSTOMER SERVICE

If you would like to order Skylink's products or have difficulty getting them to work, please :

1. visit our FAQ website at www.skylinkhome.com, or
2. email us at support@skylinkhome.com



CAPITAL PROSPECT LTD.

Rm.1303, 13/F, Block B, Veristrong Ind. Centre,
36 AuPuiWan Street, Fo Tan, Hong Kong
Tel: +852 2602-1318 Fax: +852 2602-4684
Email: support@skylinkhome.com
<http://www.skylinkhome.com>
P/N. 101A258-001 Rev.1
©2005 SKYLINK GROUP